

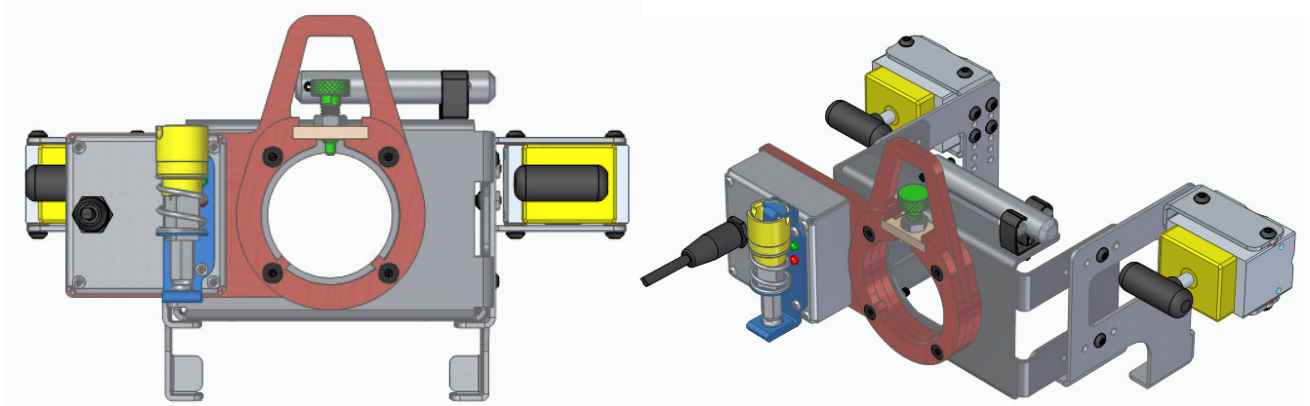

SR-U

SDB-15DSTVR-1257



Eaton

DST-15-VR

15kV

1200-2000A

Our products are built to spec in our 23,000 sq ft., state-of-the-art facility by our team of designers and engineers in Tucson, Arizona. Each product is custom designed to individually fit each breaker, cubical door, switch gear, or variant so you know you're getting the safest, most reliable product on the market. We built the best so your team stays safe.

Because Distance is the Best Arc Flash Protection



REMOTE SOLUTIONS, LLC

2475 N. Jackrabbit Avenue ■ Tucson, AZ 85745 ■ (520) 628-4378 ■ FAX (520) 628-4568 ■ Safe-T-Rack.com





Safety First

Always observe all safety precautions and use all personal protective equipment (PPE) as required by Local Site Procedures. This equipment is designed to minimize exposure risk to the operator. Please use the cables, explained below, to attain a safe distance from the breakers during racking. Always use appropriate PPE. Above all, adhere to site specific regulations and requirements.

Before beginning the racking process, be sure that the breaker is open, verify that a lockout/tag out is in place (LOTO) and allows racking of the breaker.

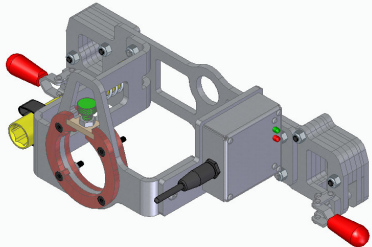
Parts List

Part/Image	Quantity	Description
	1 each	The Smart Drive Bracket (SDB) uses the Tool Adapter Assembly (TAA) to engage with the breaker and perform the racking in/out functions.
	1 each	Portable Kit includes: One Motor Drive Unit (MDU), one 50' comm. cable, two 28V batteries, and one SR-U Handheld Controller (HHC)



Operation Manual

Overview

Depicted in figs. 1.1 and 1.2, the Smart Drive Bracket (SDB) mounts to the door of the breaker using two switch magnets. Before the SDB is mounted on the front of the breaker, an Intermediate Tool Adapter (ITA), depicted in gray in its stored position atop the SDB, engages with the racking shaft through the racking port.

The Universal Tool Adapter Assembly (UTAA), seen here as a small yellow tool, couples with a Motor Drive Unit and engages with the ITA to perform the racking function.

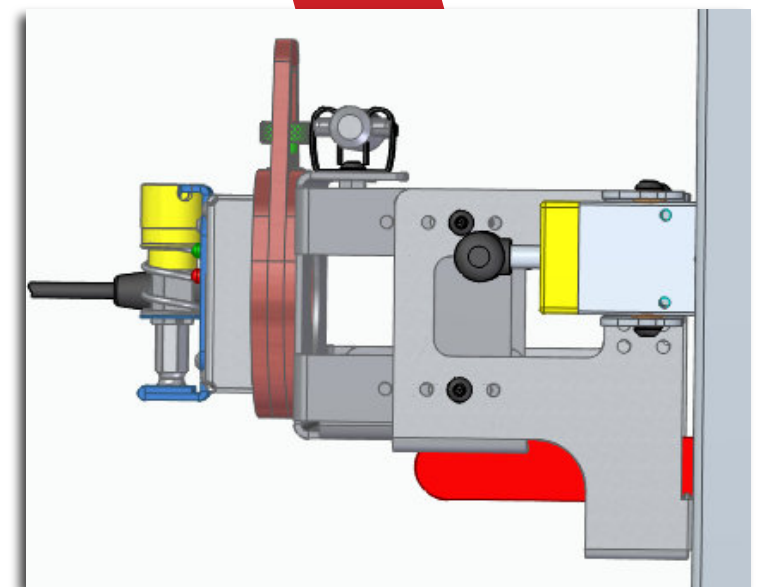

Fig. 1.1

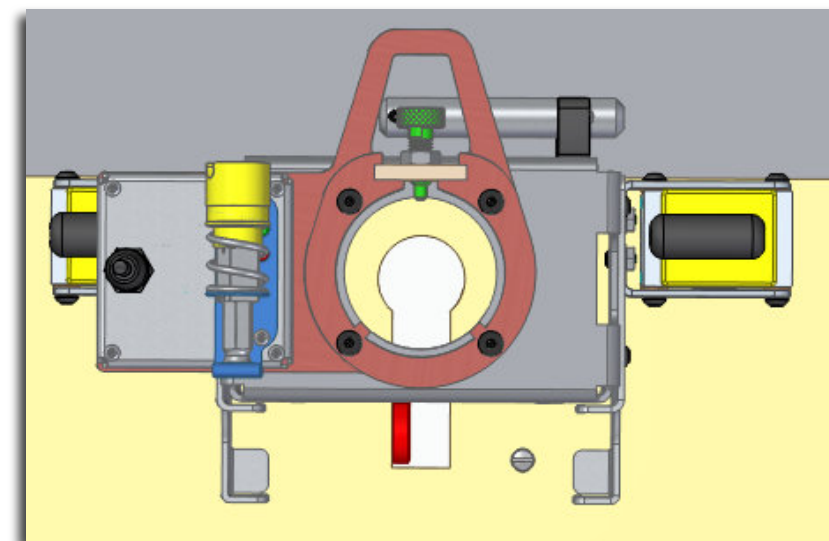

Fig. 1.2

Tool Adapter Mount

As noted in the Overview, the SDB is equipped with a Universal Tool Adapter Assembly (UTAA). The Motor Drive Unit (MDU) is equipped with a quick-connect tool coupling, which uses a collar that slides back and the UTAA inserts in to the coupling. When the coupling is released, the UTAA is secured in place. The UTAA engages with the Intermediate Tool Assembly (ITA), also stored on the SDB.

Sequence Process

1. Pull back the collar on the MDU.
2. Insert the UTAA in to the quick-connect tool coupling.
3. Release the collar and shake and twist the UTAA to ensure its locked in place.

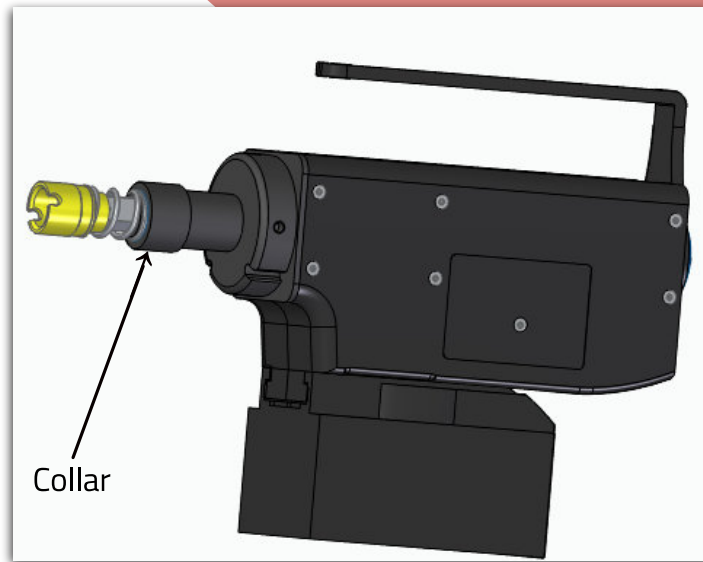

Fig. 1.3

Motor Drive Unit Mount

The Portable Kit includes two 28V batteries. Before connecting the battery to the system, make sure the battery is fully charged and is attached to the MDU. If preferred, an AC Power Supply is available, negating the need of a battery.

The MDU intuitively fits into the SDB mounting rings (depicted in red), on top of which is a locking pin (depicted in green, fig. 1.5). Set the locking pin to the open position. Insert the MDU and align the UTAA with the Intermediate Tool Adapter, then lock the MDU into place by releasing the locking pin. When the pin fully engages, the MDU is secure.

Once the MDU is secured to the SDB and fully connected to the Tool Adapter, connect the 50 foot SDB Automation Cable to the Motor Drive Unit.

Sequence Process

1. Attach a fully charged battery to the MDU.
2. Set the locking pin to the open position.
3. Insert the MDU equipped with the UTAA through the mounting rings.
4. Align and engage the UTAA with the ITA.
5. Release the locking pin, securing the MDU in place.
6. Connect the SDB Automation Cable to the MDU.

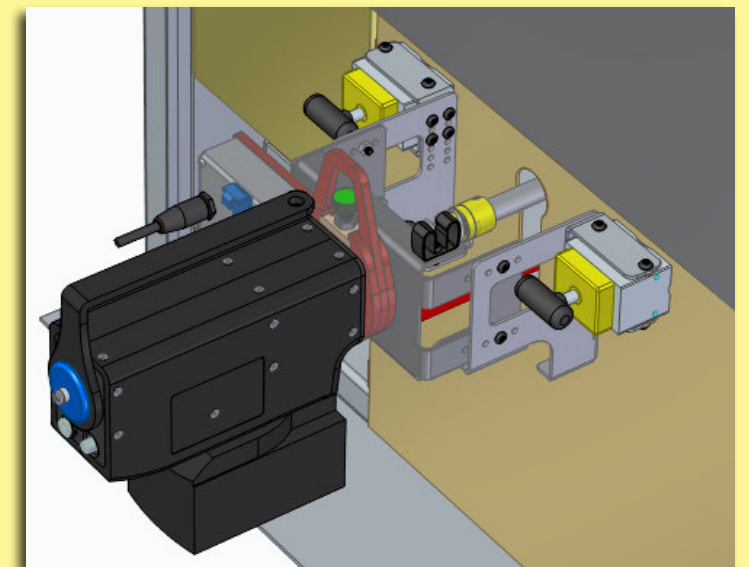

Fig. 1.5

Smart Drive Bracket Mount

Before hanging the SDB, insert the Intermediate Tool Adapter (ITA) into the racking port. To do so, open the racking port door by lifting the handle under the port. You can then insert the ITA into the port, engaging it with the racking shaft. Once the ITA is in place, the SDB mounts to the breaker door by using two switch magnets on either side of the mounting rings. Align the mounting rings with the ITA and the racking port and engage the switch magnets to secure the SDB in place.

Sequence Process

1. Lift the racking port door and insert the Intermediate Tool Adapter.
2. Align the mounting rings on the SDB in front of the ITA
3. Lock the SDB in place with the switch magnets.

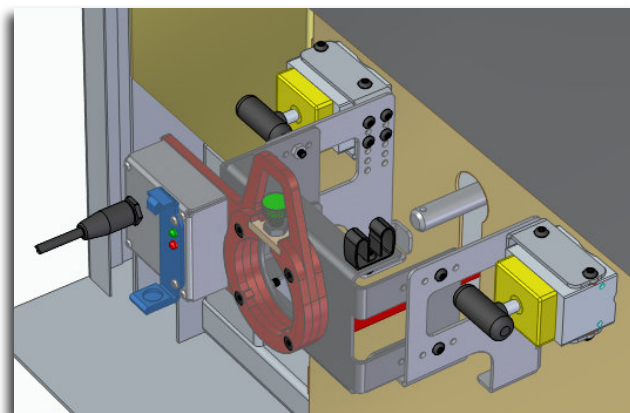

Fig. 1.4



Handheld Controller

The Handheld Controller connects to the MDU via a 50 foot Automation Cable. If necessary three cables may be tethered to achieve a safe distance of 150 feet. Once plugged in and turned on, the Handheld Controller guides the user through the racking in/out procedure.

Sequence Process

1. Connect the Handheld Controller with the 50' Comm. Cable.
2. Move a safe distance from the breaker.
3. Twist the E-Stop switch, depicted here, to activate the HCC.
4. Turn on the Handheld Controller and follow the on-screen prompts.

Error Recovery

When racking in/out, if an obstruction or mechanism failure occurs, the system will attempt to recover the breaker to a safe position. Actions will be displayed with an asterisk (*) in front of them. When done, the position of the breaker will be displayed as determined by the recovery. Note the location and approach with caution. Determine the cause of the failure and remedy the situation prior to attempting additional remote racking.

NOTE: Attempting to stop or shutting down the system mid-process once it has started is not recommended, as this will leave the breaker in an unknown position. The Remote Racking System will only operate from "known" positions: connect or disconnect. The Remote Racking System will not engage when the breaker is at a mid-point.



Care/Maintenance

To ensure longevity from the Portable Kit and the Smart Drive Bracket, store the tools in the provided polymer case in a dry, temperate environment. The tools are weather resistant but should be used with care in rain and snow.

WARNING

This product can expose you to chemicals including Di(2-ethylhexyl)phthalate (DEHP), which is known to the State of California to cause cancer and birth defects or other reproductive harm. For more information go to www.P65Warnings.ca.gov.

For any questions, concerns, information, or missing/replacement parts, contact Remote Solutions below or follow the QR link to our website.



Because Distance is the Best Arc Flash Protection

Remote Solutions, LLC

2475 N. Jackrabbit Avenue
Tucson, AZ 85745
(520) 628-4378
sales@safe-t-rack.com
www.safe-t-rack.com