

# REMOTE RACKING SYSTEM

SPECIFICALLY DESIGNED FOR:

# SAFE-T-RACK<sup>®</sup>

by Remote Solutions LLC

Because Distance is the Best Arc Flash Protection

**BREAKER:** WL\*2A/3A

**MANUFACTURER:** Siemens

**VOLTAGE:** 480V

**CURRENT:** 800A, 5000A

**BISCOTTI**

**312**



- **LIGHTWEIGHT AND PORTABLE**
- **EASY-TO-USE HANDHELD CONTROLLER**
- **STANDARD 50' CABLE (WITH OPTIONAL EXTENSIONS) ASSURES SAFE DISTANCE FROM BREAKER DURING RACKING SEQUENCE**
- **ERROR RECOVERY & EMERGENCY STOP CAPABILITY**
- **MOUNTING HARDWARE INSTALLED ON CUBICLE FACE**

## PARTS & ACCESSORIES

Smart Drive Bracket,  
Tool Adapter Assembly, Motor Drive Unit,  
and 50' Communications Cable

All of our products are designed, built to spec, and shipped from our state-of-the-art facility in Tucson, Arizona. Each product is created and tested by our knowledgeable team of designers and engineers to fit each individual breaker, cubical door, switchgear, or variant. When you choose Safe-T-Rack, you're getting the safest, most reliable product on the market.

**OUR TEAM GOES TO WORK EVERY DAY  
TO MAKE SURE YOUR TEAM  
COMES HOME SAFE.**



**REMOTE SOLUTIONS, LLC**

2475 N. Jackrabbit Avenue · Tucson, AZ 85745 · (520) 628-4378 ·  
FAX (520) 628-4568 · [www.Safe-T-Rack.com](http://www.Safe-T-Rack.com)



**BREAKER:** WL\*2A/3A

**MANUFACTURER:** Siemens

**VOLTAGE:** 480V

**CURRENT:** 800A, 5000A

## SAFETY FIRST

Always observe safety precautions and use personal protective equipment (PPE) as required by local site procedures. This equipment is designed to further minimize exposure risk to the operator.

## PARTS LIST

1. Smart Drive Bracket (SDB)
2. Tool Adapter Assembly (TAA)
3. Motor Drive Unit (MDU)
4. Two (2) batteries with charger
5. One (1) SR-U Handheld Controller (HHC)
6. 50' communication cable\*
7. Polymer Storage Case

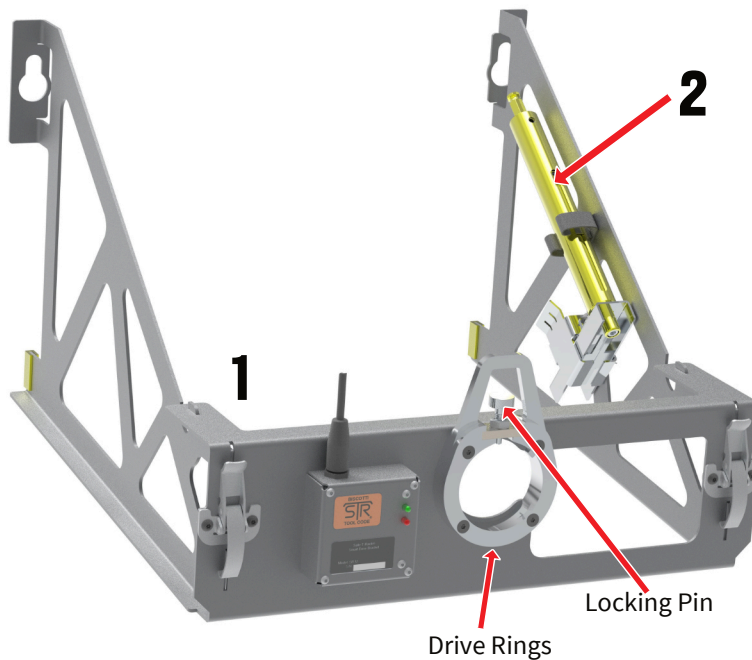

## CUBICLE KIT REQUIRED

This application requires an installed cubicle kit onto which the SDB is mounted. For questions or installation requests, contact Remote Solutions LLC.

## WARNING

This product can expose you to chemicals including Di(2-ethylhexyl), phthalate (DEHP), which is known to the State of California to cause cancer and birth defects or other reproductive harm. For more information go to [www.p65warnings.ca.gov](http://www.p65warnings.ca.gov).

# SETUP SEQUENCE

## SMART DRIVE BRACKET (SDB) & TOOL ADAPTER ASSEMBLY (TAA)

1. Suspend Smart Drive Bracket (SDB) from shoulder nuts installed on breaker face. Confirm that SDB is suspended securely.
2. Remove Tool Adapter Assembly (TAA) from storage clip on SDB and fasten TAA to racking lever of breaker.
3. Confirm that TAA is aligned with center of drive rings.

## MOTOR DRIVE UNIT (MDU)

1. Attach fully charged battery to Motor Drive Unit (MDU).
2. Set the locking pin on SDB to an open position and insert MDU into the drive rings on SDB.
3. Align and engage the MDU with the Tool Adapter Assembly (TAA). Using Quick Change Coupling, insert TAA into MDU.
4. Release locking pin to hold MDU in place. Confirm that MDU is secured in place before proceeding.
5. Connect SDB communication cable to port in MDU. Note: red line on communication cables indicates correct alignment with port.

## HANDHELD CONTROLLER (HHC)

1. Connect 50' Communication Cable to second port in MDU.
2. Connect other end of 50' Communication Cable to Handheld Controller (HHC)\*.
3. Move a safe distance away from the breaker.



**SDB SUSPENDED FROM SHOULDER BOLTS OF CUBICLE KIT**

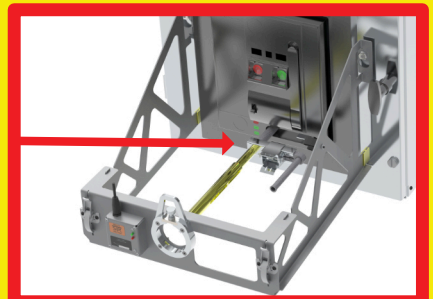

**TOOL ADAPTER ASSEMBLY ATTACHED TO RACKING LEVER ON BREAKER**

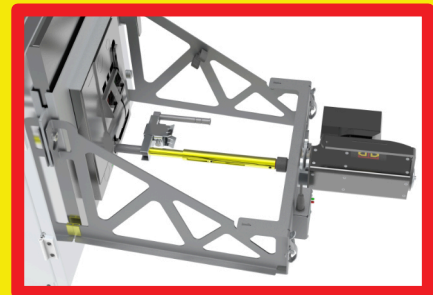

**MDU CONNECTED TO TAA WITH THE QUICK CHANGE ADAPTER**



**MDU PROPERLY ENGAGED WITH DRIVE RINGS AND LOCKING PIN, READY FOR SDB AND HHC COMMUNICATION CABLES**



## REMOTE SOLUTIONS, LLC

2475 N. Jackrabbit Avenue · Tucson, AZ 85745  
(520) 628-4378 · FAX (520) 628-4568 ·  
sales@Safe-T-Rack.com · www.Safe-T-Rack.com

\*Note: Multiple cables can be used to increase safe distance from breaker. Additional cables sold separately. Contact Remote Solutions LLC for more information.

## POWER ON

1. Twist the E-Stop switch on HHC to activate the system.
2. Several screens will flash as unit powers up. Once HHC has powered up, **verify correct application screen is displayed.**

## SYSTEM OPERATION

1. Follow the on-screen prompts to complete racking procedure. Navigate selections using perimeter buttons on HHC (backlit in green). “Right” and “Left” will advance through menu screens. “Up” and “Down” will toggle between options on screen.
2. Navigating HHC in this manner, select current location and desired destination of breaker. When selection is highlighted, click center button (backlit in red) to confirm selection. **This will initiate the racking process.**
3. System will perform action as selected, displaying progress on screen.
4. Upon successful operation, HHC will display a completed racking screen.

## POWER DOWN & STORAGE

1. Power down the unit by pressing the E-Stop button. Remove battery from MDU.
2. Unplug power cord and HHC communication cord from SDB.
3. Stow 50’ Communication Cable, HHC, MDU, and batteries in storage case.
4. Remove TAA from cubicle and return it to storage clip on SDB.
5. Remove SDB from cubicle and store in provided polymer case.

## BATTERY REQUIREMENT

Note: System will ask to verify battery level. Check battery level is at 4 bars before attempting to rack. If racking multiple breakers, please verify battery level between each racking attempt.



## CARE & MAINTENANCE

To ensure longevity of the Portable Kit and SDB, store the tools in the provided polymer case in a dry, temperate environment. The tools are weather resistant but should be used with care in rain and snow.

Remote Solutions reserves the right to change or update product or documentation without prior notice.

## ERROR RECOVERY

If a problem occurs, programmed recoveries will happen automatically and the system will attempt to recover the breaker to a known position.

When racking in/out, if an obstruction or mechanism failure occurs, the system will attempt to recover the breaker to a safe position. Actions will be displayed on HHC with an asterisk (\*) in front of them. When the HHC has completed recovery operations, HHC will display current expected location of the breaker. Note the expected location and approach the breaker with caution. Determine cause of the failure and remedy the situation prior to attempting additional remote racking.

NOTE: Attempting to stop or shutting down the system mid-process once it has started is not recommended, as this will leave the breaker in an unknown position. The Remote Racking System will only operate from known positions.



## EMERGENCY STOP

The red E-Stop button on the HHC serves as both the power and Emergency Stop button. If an E-stop is initiated, the system will shut down. Operator must then manually recover the breaker to a known position. Follow all safety procedures and wear appropriate PPE when recovering a breaker manually.

For any questions, concerns, information, or missing/replacement parts, contact Remote Solutions below or follow the QR link to our website.



**SR** **SAFE-T-RACK**  
by Remote Solutions LLC

**2475 N. Jackrabbit Avenue · Tucson, AZ 85745 · (520) 628-4378**

FAX (520) 628-4568 · sales@Safe-T-Rack.com · www.Safe-T-Rack.com