

REMOTE OPEN/CLOSE SYSTEM

SPECIFICALLY DESIGNED FOR:

BREAKER: Toshiba

MANUFACTURER: JK Contactor - Linden Cogen

VOLTAGE: 5kV

SR SAFE-T-RACK®

by Remote Solutions LLC

Because Distance is the Best Arc Flash Protection

ZULU

368



- LIGHTWEIGHT AND PORTABLE
- EASY-TO-USE HANDHELD CONTROLLER
- STANDARD 50' CABLE (WITH OPTIONAL EXTENSIONS) ASSURES SAFE DISTANCE FROM BREAKER DURING RACKING SEQUENCE
- ERROR RECOVERY & EMERGENCY STOP CAPABILITY
- NO-MOD DESIGN - NO PERMANENT ALTERATIONS TO CUBICLE

PARTS & ACCESSORIES

Remote Open/Close Device,
2 Batteries and Chargers, Handheld
Controller, and Communications Cord

All of our products are designed, built to spec, and shipped from our state-of-the-art facility in Tucson, Arizona. Each product is created and tested by our knowledgeable team of designers and engineers to fit each individual breaker, cubicle door, switchgear, or variant. When you choose Safe-T-Rack, you're getting the safest, most reliable product on the market.

**OUR TEAM GOES TO WORK EVERY DAY
TO MAKE SURE YOUR TEAM
COMES HOME SAFE.**



REMOTE SOLUTIONS, LLC

2475 N. Jackrabbit Avenue · Tucson, AZ 85745 · (520) 628-4378 ·

FAX (520) 628-4568 · www.Safe-T-Rack.com



BREAKER: Toshiba

MANUFACTURER: JK Contactor - Linden Cogen

VOLTAGE: 5kV

SAFETY FIRST

Always observe safety precautions and use personal protective equipment (PPE) as required by local site procedures. This equipment is designed to further minimize exposure risk to the operator.

PARTS LIST

1. Remote Open/Close Device (ROC)
2. Two (2) batteries with charger
3. One (1) SR-U Handheld Controller (HHC)
4. 50' communication cable*
5. Polymer Storage Case

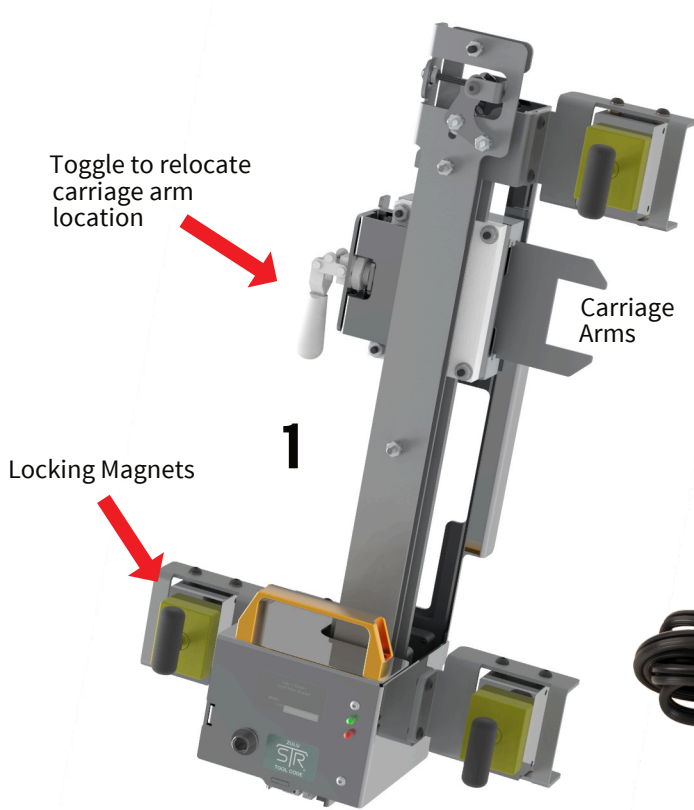

⚠️ WARNING

This product can expose you to chemicals including Di(2-ethylhexyl), phthalate (DEHP), which is known to the State of California to cause cancer and birth defects or other reproductive harm. For more information go to www.p65warnings.ca.gov.

SETUP SEQUENCE

REMOTE OPEN/CLOSE DEVICE (ROC)

1. Place ROC Device on cubicle face so that contactor Open/Close Lever is positioned within carriage arm assembly.
2. If necessary, adjust carriage location on bracket so that carriage arms align with current location of contactor lever. To adjust: use toggle on left of carriage. Loosen toggle to allow carriage movement along track and relocate carriage as needed. Tighten toggle to lock carriage in correct position. **Ensure that carriage is locked in place before proceeding.**
3. Lock magnets to hold ROC Bracket in place.
4. Adjust and lock toggle clamps on carriage arm as needed.
5. Attach fully charged Battery to ROC Bracket.

HANDHELD CONTROLLER (HHC)

1. Connect 50' Communication Cable in ROC.
2. Connect other end of 50' Communication Cable to Handheld Controller (HHC)*.
3. Move a safe distance away from the breaker.

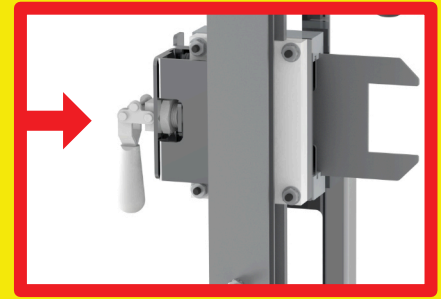

TOGGLE - ADJUSTS LOCATION OF CARRIAGE ON BRACKET TRACK



CARRIAGE ARMS CORRECTLY POSITIONED AROUND CONTACTOR OPEN/CLOSE LEVER

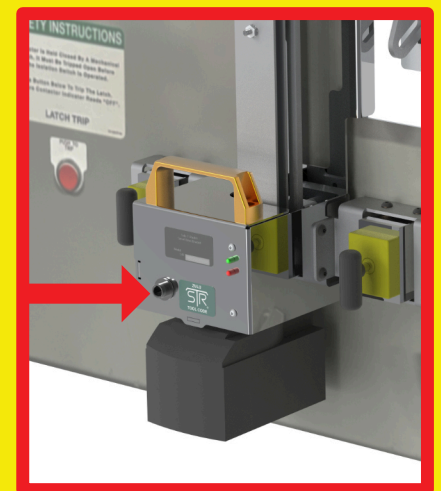

ROC BRACKET WITH BATTERY ATTACHED. PORT FOR COMMUNICATION CORD TO HHC INDICATED WITH ARROW



REMOTE SOLUTIONS, LLC

2475 N. Jackrabbit Avenue · Tucson, AZ 85745
(520) 628-4378 · FAX (520) 628-4568 ·
sales@Safe-T-Rack.com · www.Safe-T-Rack.com

*Note: Multiple cables can be used to increase safe distance from breaker. Additional cables sold separately. Contact Remote Solutions LLC for more information.

POWER ON

1. Twist the E-Stop switch on HHC to activate the system.
2. Several screens will flash as unit powers up. Once HHC has powered up, **verify correct application screen is displayed.**

SYSTEM OPERATION

1. Follow the on-screen prompts to complete racking procedure. Navigate selections using perimeter buttons on HHC (backlit in green). “Up” and “Down” will toggle through options on screen. “Right” and “Left” will confirm selections.
2. Navigating HHC in this manner, select current location and desired destination of breaker. When selection is highlighted, click center button (backlit in red) to confirm selection. **This will initiate the racking process.**
3. System will perform action as selected, displaying progress on screen.
4. Upon successful operation, HHC will display a completed racking screen.

POWER DOWN & STORAGE

1. Power down the unit by pressing the E-Stop button. Remove battery from ROC.
2. Unplug power cord and HHC communication cord from SDB. Remove battery from ROC.
3. Stow 50’ Communication Cable, HHC, and batteries in storage case.
4. Release magnets and remove ROC from cubicle and store in provided polymer case.

BATTERY REQUIREMENT

Note: System will ask to verify battery level. Check battery level is at 4 bars before attempting to rack. If racking multiple breakers, please verify battery level between each racking attempt.



CARE & MAINTENANCE

To ensure longevity of the Portable Kit and SDB, store the tools in the provided polymer case in a dry, temperate environment. The tools are weather resistant but should be used with care in rain and snow.

Remote Solutions reserves the right to change or update the product or information without prior notice.

ERROR RECOVERY

If a problem occurs, programmed recoveries will happen automatically and the system will attempt to recover the breaker to a known position.

When racking in/out, if an obstruction or mechanism failure occurs, the system will attempt to recover the breaker to a safe position. Actions will be displayed on HHC with an asterisk (*) in front of them. When the HHC has completed recovery operations, HHC will display current expected location of the breaker. Note the expected location and approach the breaker with caution. Determine cause of the failure and remedy the situation prior to attempting additional remote racking.

NOTE: Attempting to stop or shutting down the system mid-process once it has started is not recommended, as this will leave the breaker in an unknown position. The Remote Racking System will only operate from known positions.

EMERGENCY STOP

The red E-Stop button on the HHC serves as both the power and Emergency Stop button. If an E-stop is initiated, the system will shut down. Operator must then manually recover the breaker to a known position. Follow all safety procedures and wear appropriate PPE when recovering a breaker manually.

For any questions, concerns, information, or missing/replacement parts, contact Remote Solutions below or follow the QR link to our website.



2475 N. Jackrabbit Avenue · Tucson, AZ 85745 · (520) 628-4378

FAX (520) 628-4568 · sales@Safe-T-Rack.com · www.Safe-T-Rack.com