

# REMOTE RACKING SYSTEM

SPECIFICALLY DESIGNED FOR:

# SR SAFE-T-RACK<sup>®</sup>

by Remote Solutions LLC

Because Distance is the Best Arc Flash Protection

**BREAKER:** DHP/DHP-VR

**MANUFACTURER:** Westinghouse, Cutler-Hammer

**VOLTAGE:** 5kV, 15kV

**CURRENT:** 1200A, 3000A

**CAROB**

**214**

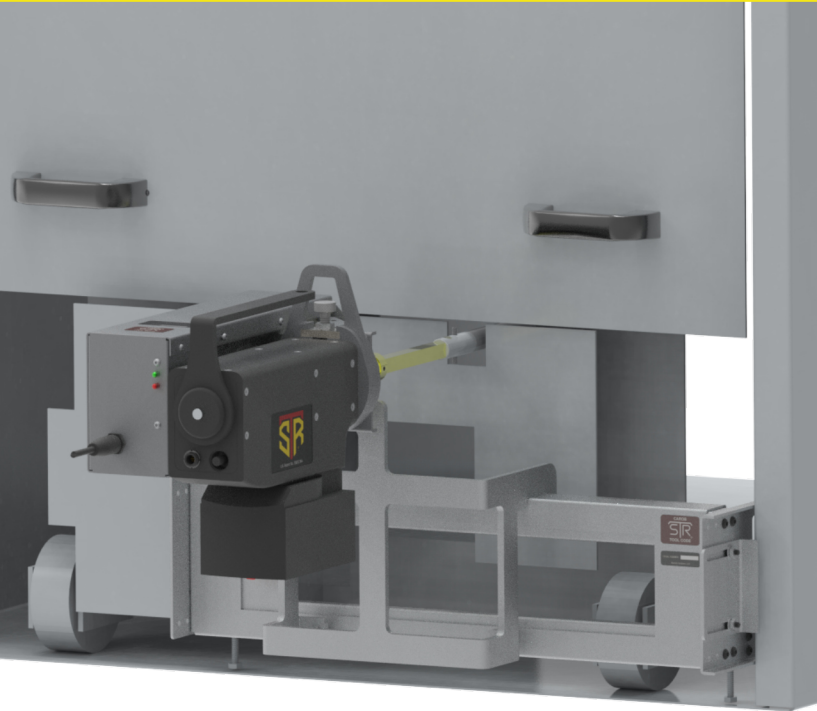

- LIGHTWEIGHT AND PORTABLE
- EASY-TO-USE HANDHELD CONTROLLER
- STANDARD 50' CABLE (WITH OPTIONAL EXTENSIONS) ASSURES SAFE DISTANCE FROM BREAKER DURING RACKING SEQUENCE
- ERROR RECOVERY & EMERGENCY STOP CAPABILITY
- NO-MOD DESIGN MEANS NO PERMANENT ALTERATIONS TO EQUIPMENT OR BREAKER

## PARTS & ACCESSORIES

Smart Drive Bracket,  
Tool Adapter Assembly, Motor Drive Unit,  
Handheld Controller,  
and 50' Communications Cable

All of our products are designed, built to spec, and shipped from our state-of-the-art facility in Tucson, Arizona. Each product is created and tested by our knowledgeable team of designers and engineers to fit each individual breaker, cubicle door, switchgear, or variant. When you choose Safe-T-Rack, you're getting the safest, most reliable product on the market.

**OUR TEAM GOES TO WORK EVERY DAY  
TO MAKE SURE YOUR TEAM  
COMES HOME SAFE.**



**REMOTE SOLUTIONS, LLC**

2475 N. Jackrabbit Avenue · Tucson, AZ 85745 · (520) 628-4378 ·  
FAX (520) 628-4568 · [www.Safe-T-Rack.com](http://www.Safe-T-Rack.com)



**BREAKER:** DHP/DHP-VR

**MANUFACTURER:** Westinghouse, Cutler-Hammer

**VOLTAGE:** 5kV, 15kV

**CURRENT:** 1200A, 3000A

## SAFETY FIRST

Always observe safety precautions and use personal protective equipment (PPE) as required by local site procedures. This equipment is designed to further minimize exposure risk to the operator.

## PARTS LIST

1. Spanner Bar
2. Smart Drive Bracket (SDB)
3. Motor Drive Unit (MDU)
4. Tool Adapter Assembly (TAA)
5. One (1) SR-U Handheld Controller (HHC)
6. 50' Communication Cable\*
7. Two (2) batteries with charger
8. Polymer Storage Case

8



Navigation & Selection Buttons

5



Power/E-Stop Button

6

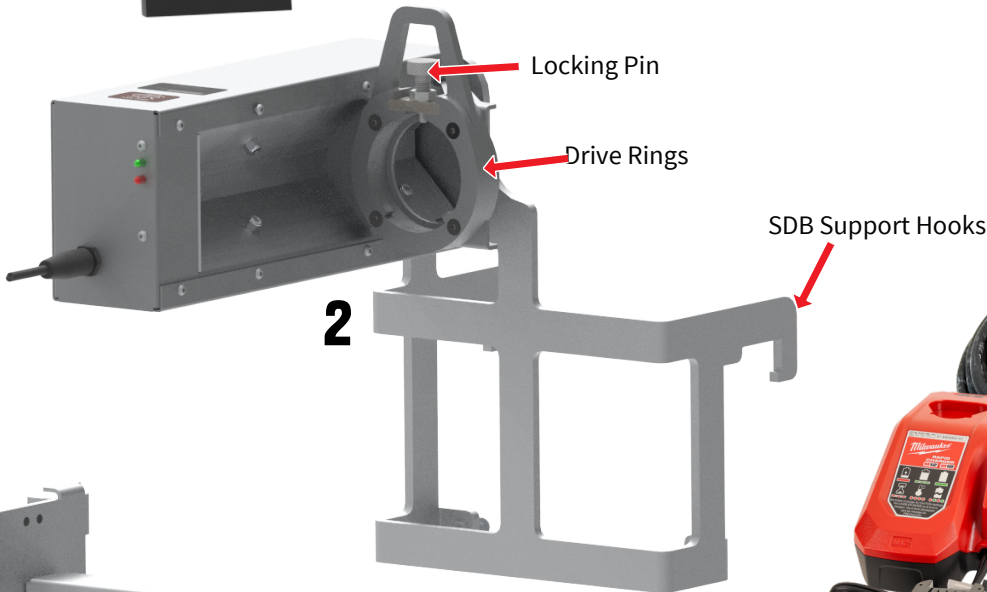

2



7

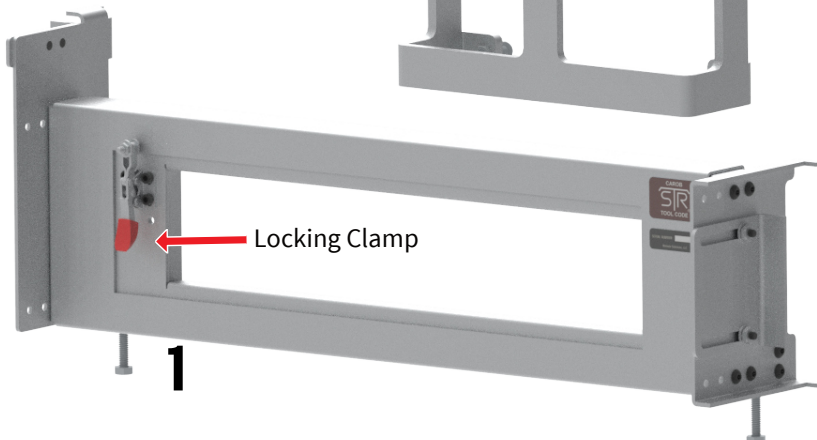

Locking Clamp

1

### WARNING

This product can expose you to chemicals including Di(2-ethylhexyl), phthalate (DEHP), which is known to the State of California to cause cancer and birth defects or other reproductive harm. For more information go to [www.p65warnings.ca.gov](http://www.p65warnings.ca.gov).

# SETUP SEQUENCE

## SMART DRIVE BRACKET (SDB) & SPANNER BAR

1. Assure that cubicle, Spanner Bar, and Smart Drive Bracket (SDB) are all labeled with CAROB color code.
2. Place Spanner bar across cubicle and adjust it to fit across cubicle at floor level. Once aligned correctly, use locking clamps to secure spanner bar in place.
3. Hang SDB from spanner bar using support hooks so that drive rings align with racking shaft.

## MOTOR DRIVE UNIT (MDU) & TOOL ADAPTER ASSEMBLY (TAA)

1. Using Quick Change Coupling, insert Tool Adapter Assembly (TAA) into Motor Drive Unit (MDU) and release collar. Assure that TAA is secured before proceeding.
2. Attach fully charged battery to MDU.
3. Set the locking pin on SDB to an open position and insert MDU into the drive rings on SDB.
4. Align and engage the MDU with ring dogs on drive rings. Once aligned, release locking pin to hold MDU in place. Confirm that MDU is secured before proceeding.
5. Connect SDB communication cable to port in MDU.  
*Note: Red line on communication cables indicates correct alignment with port.*

## HANDHELD CONTROLLER (HHC)

1. Connect 50' Communication Cable to second port in MDU.
2. Connect other end of 50' Communication Cable to Handheld Controller (HHC)\*.
3. Move a safe distance away from the breaker.

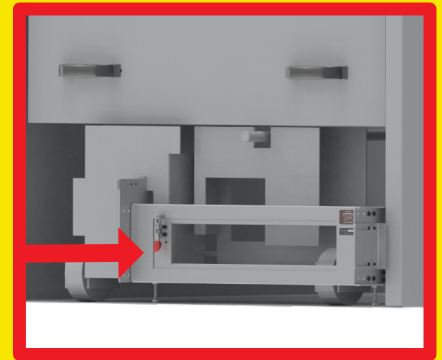

**SPANNER BAR PLACED ACROSS CUBICLE WITH LOCKING CLAMPS ENGAGED TO HOLD IT IN PLACE**

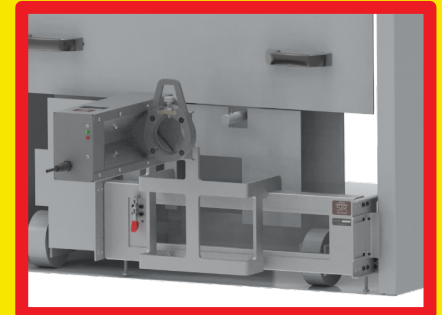

**SDB SUSPENDED FROM SPANNER BAR**



**MDU WITH ATTACHED TAA**

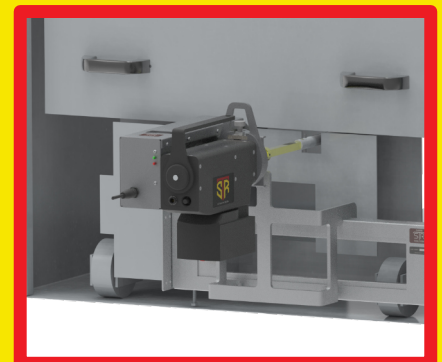

**MDU ENGAGED WITH DRIVE RINGS, READY FOR SDB AND HHC COMMUNICATION CORDS**

\*Note: Multiple cables can be used to increase safe distance from breaker. Additional cables sold separately. Contact Remote Solutions LLC for more information.

## POWER ON

1. Twist the E-Stop switch on HHC to activate the system.
2. Several screens will flash as unit powers up. Once HHC has powered up, **verify correct application screen is displayed.**

## SYSTEM OPERATION

1. Follow the on-screen prompts to complete racking procedure. Navigate selections using perimeter buttons on HHC (backlit in green). “Right” and “Left” will advance through menu screens. “Up” and “Down” will toggle selections on screen.
2. Navigating HHC in this manner, select current location and desired destination of breaker. When selection is highlighted, click center button (backlit in red) to confirm selection. **This will initiate the racking process.**
3. System will perform action as selected, displaying progress on screen.
4. Upon successful operation, HHC will display a completed racking screen.

## POWER DOWN & STORAGE

1. Power down the unit by pressing the E-Stop button. Remove battery from MDU.
2. Unplug power cord and HHC communication cord from SDB.
3. Remove TAA from MDU and store in case.
4. Stow 50’ Communication Cable, HHC, MDU, and batteries in storage case.
5. Remove SDB and Spanner Bar from cubicle and store in provided polymer case.

## BATTERY REQUIREMENT

Note: System will ask to verify battery level. Check battery level is at 4 bars before attempting to rack. If racking multiple breakers, please verify battery level between each racking attempt.



## CARE & MAINTENANCE

To ensure longevity of the Portable Kit and SDB, store the tools in the provided polymer case in a dry, temperate environment. The tools are weather resistant but should be used with care in rain and snow.

Remote Solutions reserves the right to change or update product or documentation without prior notice.

## ERROR RECOVERY

If a problem occurs, programmed recoveries will happen automatically and the system will attempt to recover the breaker to a known position.

When racking in/out, if an obstruction or mechanism failure occurs, the system will attempt to recover the breaker to a safe position. Actions will be displayed on HHC with an asterisk (\*) in front of them. When the system has completed recovery operations, HHC will display current expected location of the breaker. Note the expected location and approach the breaker with caution. Determine cause of the failure and remedy the situation prior to attempting additional remote racking.

NOTE: Attempting to stop or shutting down the system mid-process once it has started is not recommended, as this will leave the breaker in an unknown position. The Remote Racking System will only operate from known positions.



## EMERGENCY STOP

The red E-Stop button on the HHC serves as both the power and Emergency Stop button. If an E-stop is initiated, the system will shut down. Operator must then manually recover the breaker to a known position. Follow all safety procedures and wear appropriate PPE when recovering a breaker manually.

For any questions, concerns, information, or missing/replacement parts, contact Remote Solutions below or follow the QR link to our website.



**SR** **SAFE-T-RACK**  
by Remote Solutions LLC

**2475 N. Jackrabbit Avenue · Tucson, AZ 85745 · (520) 628-4378**

FAX (520) 628-4568 · sales@Safe-T-Rack.com · www.Safe-T-Rack.com